

Magnum Combination Unit – MTT20 Specifications

ENGINE

- Isuzu® 4LE1-PV05 - liquid cooled, diesel engine
 - Standby - 34.5 hp @ 1800 rpm
 - Prime - 31.5 hp @ 1800 rpm
 - 4 cylinder
 - 2.20 L displacement
- Fuel consumption (prime) – 1.80 gph (6.81 Lph)
- 60 Hz engine/generator
- Industrial engine exhaust system
- Rubber vibration dampers isolate engine/generator from frame
- Cooling system capable of operating at 120°F ambient
- Full flow oil filter, spin on type
- Fuel filter with replaceable element
- Dry type cartridge air filter

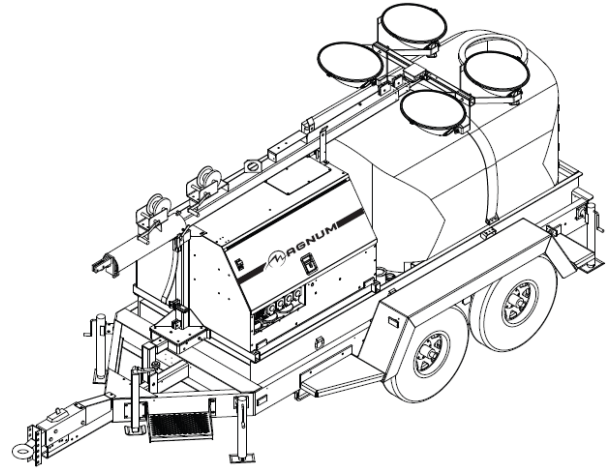

ENGINE CONTROLS

- Engraved, aluminum punched and anodized control panel
- Four position keyed switch – glow plugs (preheat, off, run, start)
- Hour meter
- Automatic low oil/high temperature shutdown system

GENERATOR

- Marathon Electric®
 - Brushless
- 20 kW prime output
- 120/240 VAC – 167/83A
- +/-1% voltage regulation

ELECTRICAL SYSTEM AND CONTROLS

- Individual floodlight circuits with 15A breakers
- Ballast indicator lights
- 100A start limit breaker (assures no load condition exists before starting)
- Standard individually breakered convenience outlets:
 - (2) 120 VAC 20 Amp GFCI duplex outlets (Nema 5-20R type)
 - (2) 240 VAC 30 Amp twistlock outlets (Nema L6-30R type)
 - (2) 240 VAC 50 Amp twistlock outlets (Non Nema 6369)
- 720 CCA wet cell battery

FLOODLIGHTS

- Four light fixtures – 1000 watts each - metal halide, quick disconnect
- Oval aluminum reflector
- Tempered glass lens
- Silicone gaskets for moisture and dust protection
- Individual floodlight On/Off switches

WIRING

- All wiring is sized to the amperage draw required
- AC & DC wiring diagrams are provided

LIGHT TOWER ENCLOSURE

- Steel enclosure – 14-gauge
 - UV& fade resistant, high temperature cured, white polyester powder paint
 - 68 dB(A) at 23 feet – prime power
- Stainless steel hinges on doors
- Multi-lingual operating/safety decals
- License plate holder with light
- Manual holder with operating/parts manuals

MAST

- 30' maximum extension, 3-section, tubular steel
- Self-lubricating, graphite guides on all sides of mast tubes
- Industrial black powder coat finish
- Automatic locking system in horizontal position for travel
- 1500 lb. automatic self-braking winches
- 360° rotation with locking system
- Coiled mast cord
- Dual winch system located at ergonomic height allowing single person operation
- Equipped with single lifting eye and fork pockets

WATER TANK & PUMP

- 500 gallon capacity
- ShurFLO® pump
 - 3.3 gpm (12.5 Lpm) - flow rate
 - 3.0 gpm (11.4 Lpm) - flow rate at hose bibb
- Hose bibb connections include (2) gravity and (2) pump

TRAILER

- Steel, single wall fuel tank
 - 246 gal. capacity
 - 127 hr. run time – full load
 - Fuel tank built into skid of generator set
- DOT approved tail, side, brake, and directional lights
 - Recessed rear lights
- Transportation tie downs
- Safety chains with spring loaded safety hooks



- 3" lunette ring hitch
- (2) 6000 lb. axles with surge brakes
- 5000 lb. tongue jack with footplate
- 7.50x16E-6-W tubeless tires – 10 ply

WEIGHTS & DIMENSIONS

- Dry weight: 5160 lbs (2341 kg)
- Operating weight: 10900 lbs (4944 kg)
- Mast stowed: 210 x 86 x 83 in (5.30 x 2.18 x 2.10 m)

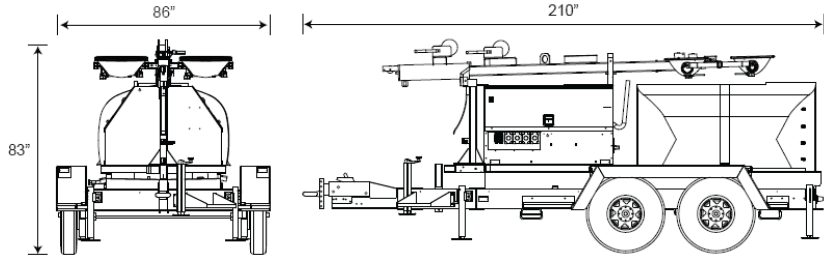

WARRANTY

- Engine and generator covered under OEM warranty – consult factory for details.

CERTIFICATIONS

- CSA certified

MTT20 Options

COOLANT OPTIONS

- ◆ 60/40 Coolant, 60% Ethylene glycol

ENGINE OPTIONS

- ◆ Heated fuel filter
- ◆ Lower radiator hose – engine heater

ELECTRICAL CONTROLS OPTIONS

- ◆ 720 CCA gel cell battery
- ◆ 685 CCA gel cell battery
- ◆ Battery disconnect
- ◆ Battery charger – 2A trickle
- ◆ Autolight controller
- ◆ Alternative receptacle panel – consult factory for configurations

CABINET OPTIONS

- ◆ Interior cabinet light
- ◆ Level indicator
- ◆ Containment/quiet pack
- ◆ Tamper pack

WATER TANK OPTIONS

- ◆ White water tank
- ◆ 120V pump heater



HITCH OPTIONS

- ◆ 2" ball
- ◆ 2 5/16" ball

TRAILER OPTIONS

- ◆ Spare tire and carrier
- ◆ Electric brakes

LIGHT OPTIONS

- ◆ High pressure sodium, quick disconnect lights

MAST CORD OPTIONS

- ◆ Drape cord

MAST, WINCH, & FINISH OPTIONS

- ◆ Galvanized, manual, dual winch
- ◆ Galvanized, electric, dual winch
- ◆ Galvanized, electric, dual winch, quick disconnect
- ◆ Black, electric, dual winch
- ◆ Black, electric, dual winch, quick disconnect

