

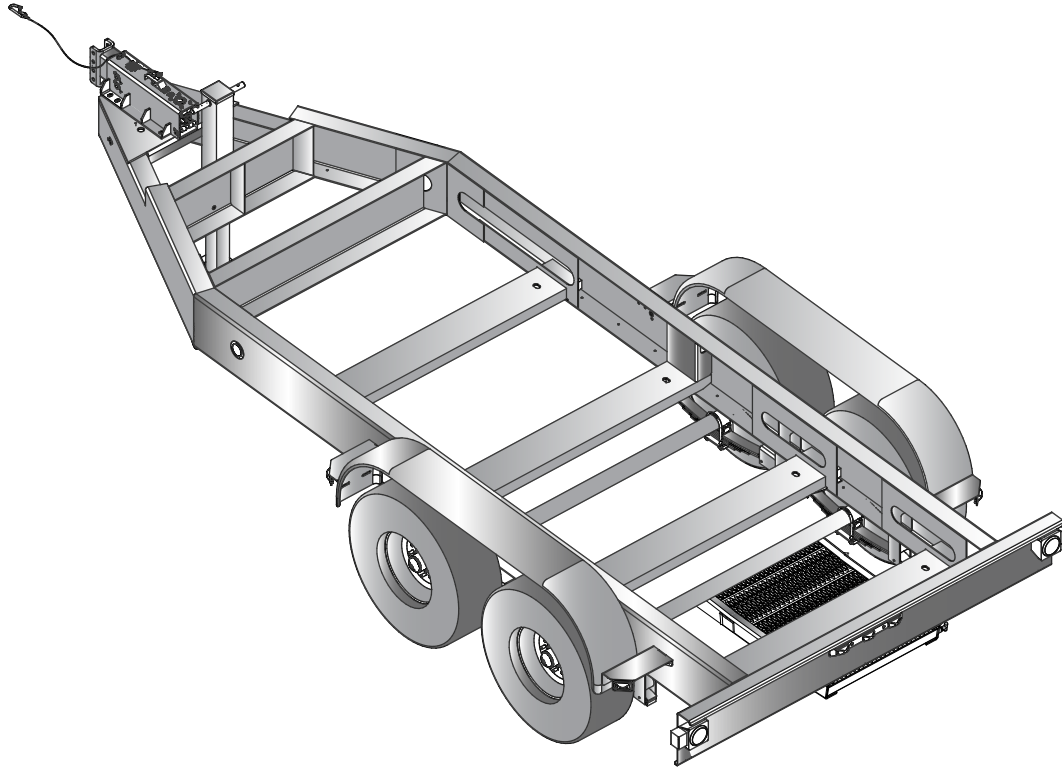

TRLR180EV

MQ POWER Tandem Axle Trailer



TRLR180EV Technical Data

Gross Vehicle Weight Rating (GVWR) — 14,000 lbs. (6,350 kg)	Tire Size — ST235/80R16 LR-G
Gross Axle Weight Rating (GAWR) — 7,000 lbs /3,175 kg (ea.)	Wheel Bolt Pattern — 8 Lug on 6.5 in
Actuator Rating — 20,000 (9.072 kg)	Tire Load Rating — 3,520 lbs /1,596 kg (ea.)
Coupler Rating — See coupler options on back page.	Dimensions (LxWxH) — See back page

STANDARD TRAILER EQUIPMENT

- Fits MQ Power Generator Models DCA150SSJU4F2 and DCA180SSJU4F
- Straight Tandem-axle Design with Leaf Spring Suspension
- Heavy-Duty Welded Steel Frame Construction
- Formed Channel for Generator Mounting and Support
- Replaceable, Bolt-on Hydraulic Brake Actuator
- 4-hole Channel Allows 3-position, Adjustable Coupler Height; 4-inches O/A
- Heavy-duty, Tongue Mounted, Drop-leg Jack (rated 10,000 lbs/4,536 kg lift)
- Replaceable, Bolt-on Steel Fenders and Brackets
- Rugged Textured Black Powder-Coated Frame, Channel, Actuator and Fenders
- D.O.T. Approved Tail Lamps, Stop Lamps, Turn Signal Lamps, Side Marker Lamps
- Weatherproof, Rubber Armored, 3-piece Trailer Light Wiring Harness
- Surge Hydraulic-actuated Drum Brakes (all axles)
- Hydraulic Uni-servo Drum Brakes — 12-inch Cluster
- D.O.T. Steel Brake Lines, Brass Tees and Rubber Hydraulic Brake Hoses
- Heavy-Duty Rear Sliding Platform with Spring-Loaded Locking Pin



TRLR180EV

MQ POWER Tandem Axle Trailer

OPTIONAL TRAILER EQUIPMENT

- Bolt-on Electric Brake Coupler Plate with Electric-actuated Drum Brakes (all axles — self-adjusting brake actuators)
- Electric Breakaway Safety Device (electric-actuated brakes)
- Rear Stabilizer Stands
- Spare Tire with Locking Mount
- Anti-Theft Wheel Lock

Coupler Options

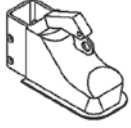
3" Pintle Eye 25,000 lbs. #EE36264	
2-5/16" Ball Coupler 20,000 lbs. #EE56770	

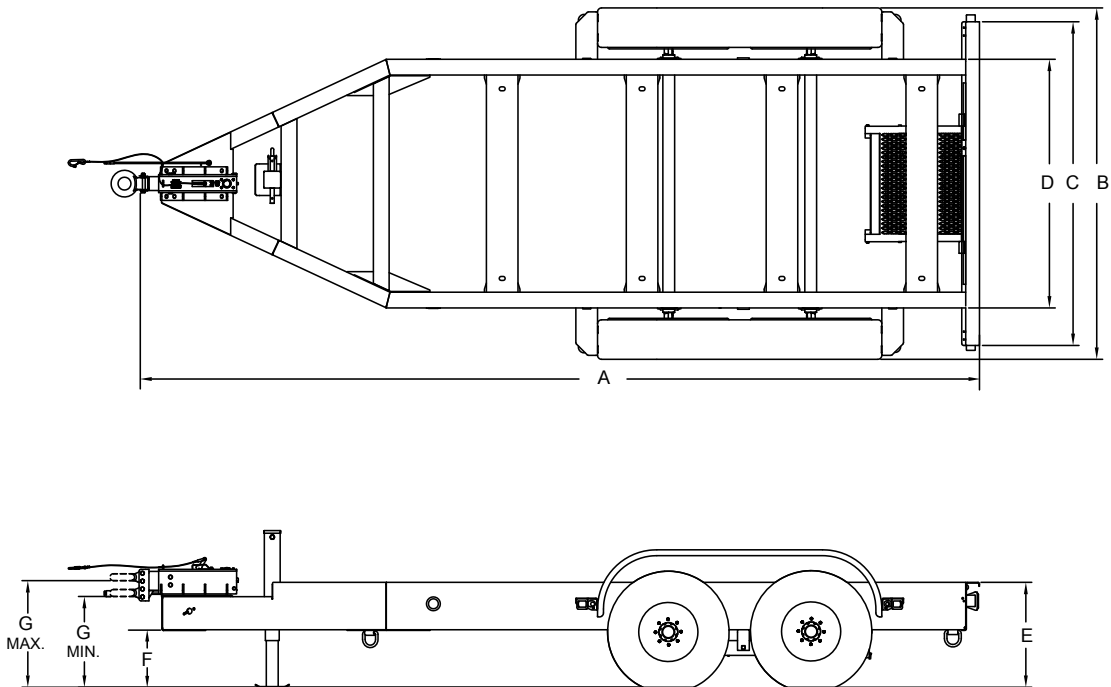

Trailer Dimensions							
A	B	C	D	E	F	G	
						Min	Max
212.9 in (5,408 mm)	89 in (2,261 mm)	82 in (2,083 mm)	63 in (1,600 mm)	26.58 in (675 mm)	14.4 in (365 mm)	23.01 in (584 mm)	27.01 in (686 mm)

Trailer Weight
2,404 lbs. (1090 kg)*

* Weight is approximate